

**THE NORTH LONDON INDEPENDENT GIRLS'
SCHOOLS' CONSORTIUM**

Group 2

YEAR 7

ENTRANCE EXAMINATION

MATHEMATICS

Friday 11 January 2013

Time allowed: 1 hour 15 minutes

First Name:

Surname:

Instructions:

- Please write in pencil.
- Please try **all** the questions.
If you cannot answer a question, go on to the next one.
- Do your rough working in the space near each question.
Do not rub out your working as you may get marks for it.
- Calculators and rulers are NOT allowed.

	△
	□
	⬠
	○

1. Work out $3456 + 789$

Answer:

2. Work out $3456 - 789$

Answer:

3. Work out 418×7

Answer:

4. Work out $2394 \div 9$

Answer:



5. (a) Write in figures the number *twenty thousand and thirteen*.

Answer:

(b) Which number is multiplied by 100 to give 2907?

Answer:

6. Which number between 40 and 50 is a multiple of both 4 and 6?

Answer:

7. Circle the number which will be in the middle when the numbers below are written in size order.

1.905 1.05 0.905 1.005 1.095

8. Work out $\frac{3}{5}$ of 45

Answer:

9. Circle the three numbers in the list below which have a sum of 43

5 8 11 14 21 31



10. A packet of 7 Doggy Chews costs £3.43
- (a) What is the cost of one Doggy Chew?
- Give your answer in pence.

Answer: p

Charlotte buys 2 packets of Doggy Chews and pays with a £20 note.

- (b) How much change should she receive?

Answer: £

11. The thermometers below show the temperatures inside and outside a window at midday, one day in winter.

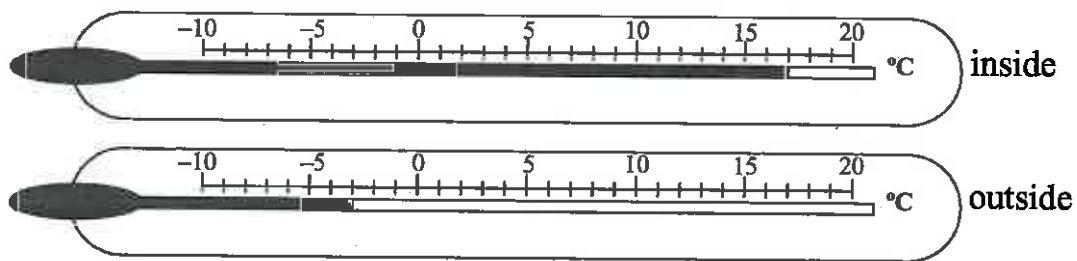

- (a) How many degrees warmer is it inside than outside the window?

Answer: degrees

At midnight, the temperature outside had fallen by 2 degrees.

- (b) What was the temperature outside the window at midnight?

Answer: °C



12. Fill in the gaps in the calculations below.

(a) $4 \times \square + 8 = 44$

(b) $3 \times (5 - \square) = 12$

(c) $40 \div \square = 4^2 \div 2$

13. (a) Shade 75% of this regular octagon.

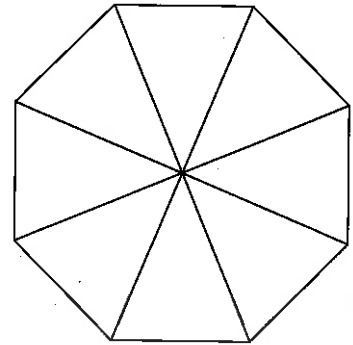

(b) Shade $\frac{5}{8}$ of this regular octagon.

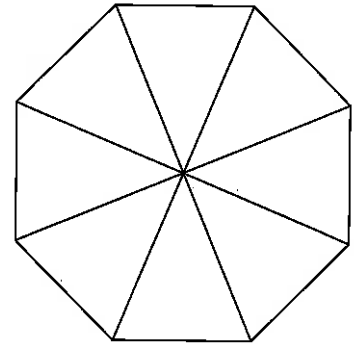

(c) Which is larger, 75% or $\frac{5}{8}$?
Give a reason for your answer.

Answer: because

.....



14. (a) The number machine below adds 3 to the input number and then multiplies by 2

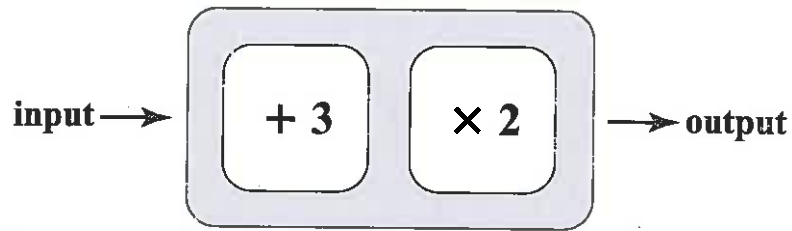

Complete the input and output table for this machine.

example:

input	output
1	8
0
.....	14

(b) A different number machine produces the input and output table below.

input	output
0	3
1	5
2	7

What is the rule for this number machine?

Answer: then



15. Mabel found her grandmother's recipe to make scones.
Here are the ingredients needed to make 12 scones:

To make 12 scones
200 g self-raising flour
pinch of salt
60 g butter
30 g caster sugar
150 ml milk

- (a) If Mabel wants to make 18 scones,
(i) how many grams of self-raising flour will she need?

Answer: g

- (ii) how many grams of caster sugar will she need?

Answer: g

Mabel only has 1.5 kilograms of flour, but has plenty of all of the other ingredients.

- (b) What is the largest number of scones which she can make?

Answer:

-
16. Jennie and Freddie have each thought of a number.

The difference between their numbers is 8

The sum of their numbers is 30

What are the two numbers?

Answer: and



17. George is 2 years and 9 months older than his sister Sophie.
George is 12 years and 5 months old.
How old is Sophie?

Answer: years months

18. Kathy has used her calculator to find out that $13 \times 641 = 8333$
Use Kathy's calculation to work out

(a) 130×641

Answer:

(b) 13×640

Answer:

(c) 23×641

Answer:



283008

8

19. Here are 5 number cards:



The 5 cards can be placed in order to form a 5-digit number.

For example, the smallest number which could be made using all 5 cards is

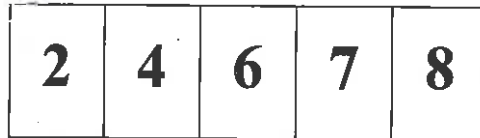

(a) Using all 5 cards,

(i) what is the largest possible odd number?

Answer:

(ii) what is the number that is closest to 50 000?

Answer:

(b) Using only 2 of the cards, what is the largest possible prime number?

Answer:

(c) Arrange any 3 of the number cards to give the largest possible answer to this multiplication.

$$\square \square \times \square$$

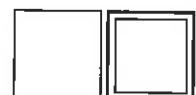

20. (a) Draw all of the lines of symmetry on the shape below.

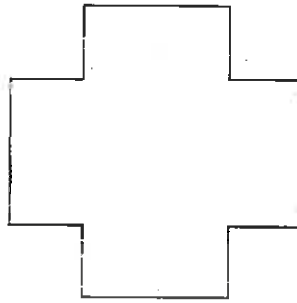

(b) Reflect the shape below in the dashed line.

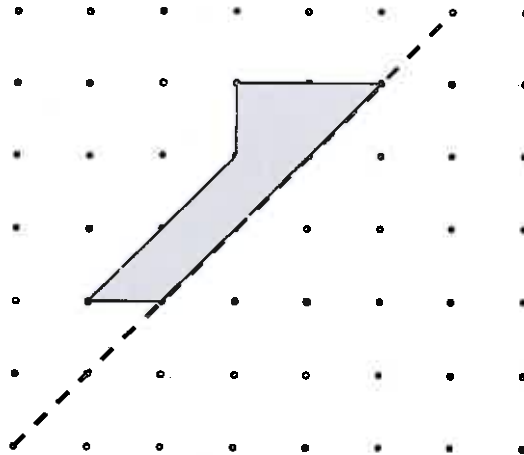

(c) Add one square to the picture drawn on the dotted grid below, so that the finished shape has exactly one line of symmetry.

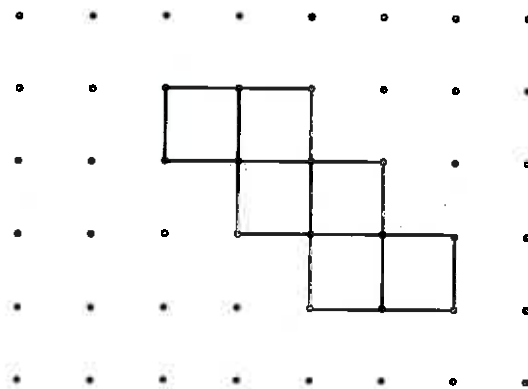

21. The diagram below shows 2 pieces of uncooked spaghetti.

piece A 

piece B 

If the length of piece A is 5 units, estimate the length of piece B.

Answer: units

22. Billy has designed the tile shown below.

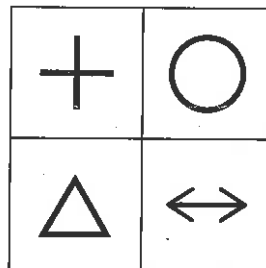

(a) Complete the grid below to show the tile if it is rotated through a quarter turn clockwise.

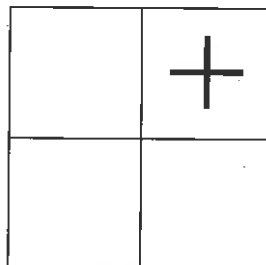

(b) Billy decides to reflect the tile in the dashed line shown below, and then rotate it through half a turn.

Draw the resulting tile on the grid below. You may complete the middle tile if you wish.

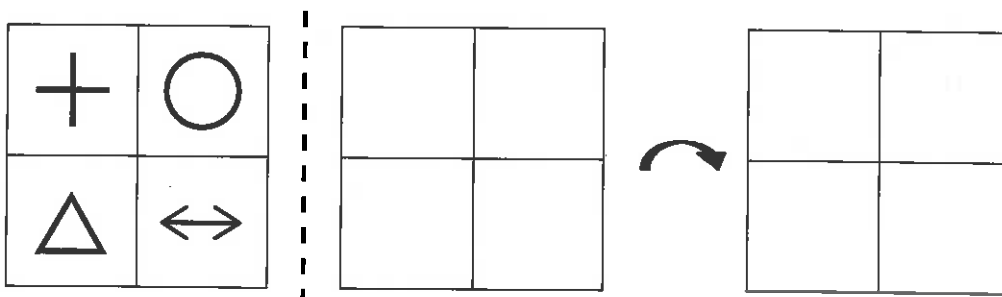

23. (a) Shape S is drawn on the centimetre-squared grid below.

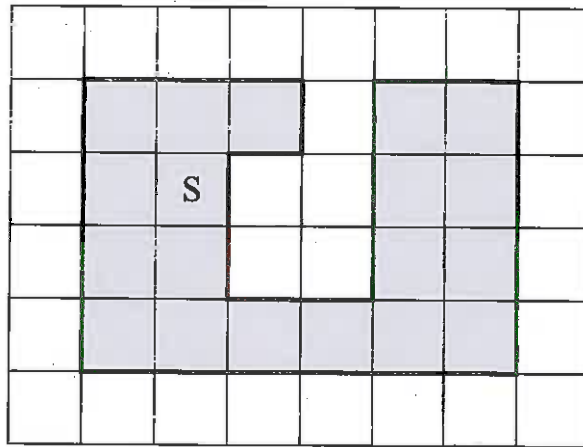

(i) What is the perimeter of shape S?

Answer: cm

(ii) What is the area of shape S?

Answer: cm²

(b) On the centimetre-squared grid below, draw a triangle with area 21 cm².

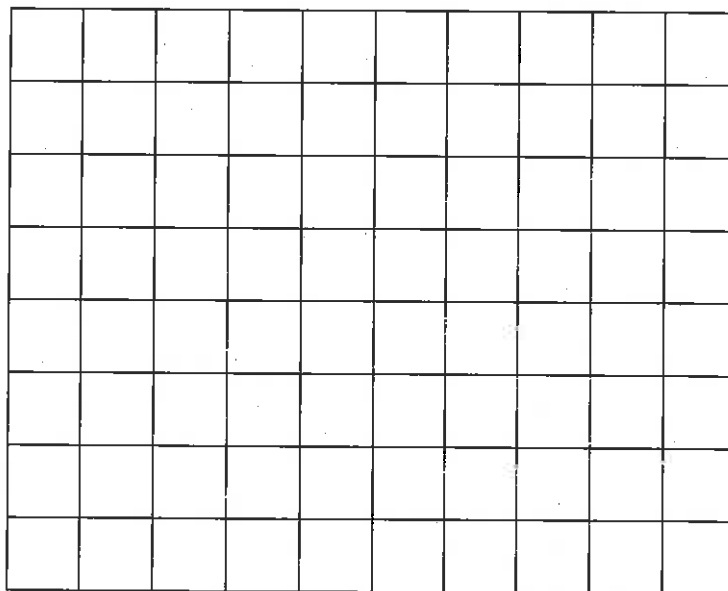

24. Point A has been plotted on the coordinate grid below.

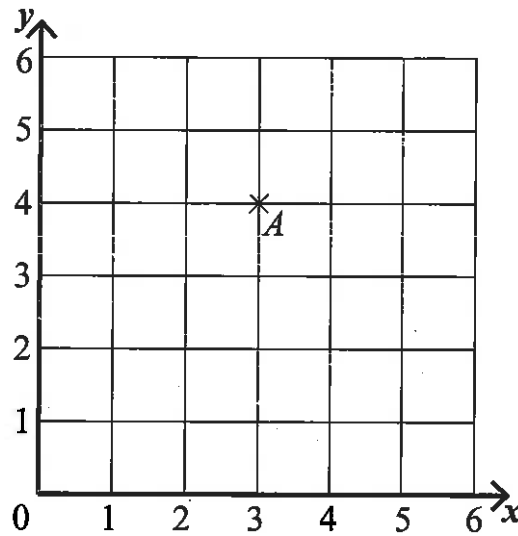

(a) Write down the coordinates of point A .

Answer: (..... ,)

Point B has coordinates $(2, 1)$.

Point C has coordinates $(5, 2)$.

(b) Plot and label points B and C .

Point D can be plotted so that when point A , B , C and D are joined in order, they form a rhombus.

(c) Write down the coordinates of the point D .

Answer: (..... ,)



25. Janice has a cube with 2 grey faces and 4 white faces.
The 2 grey faces are opposite each other.

(a) Complete the diagram to show a possible net for the cube.

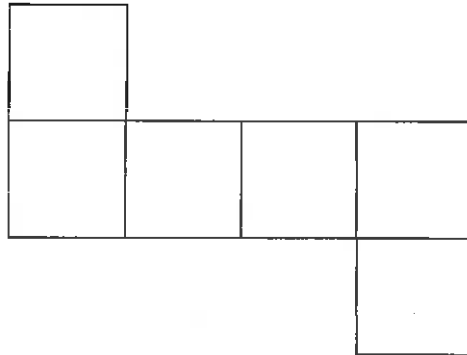

(b) If the cube is rolled 60 times, how many times would you expect to see a grey face on the top?

Answer:

Janice rolls the cube once.

(c) Draw an arrow on the scale below to show the probability that it will stop with a white face on the top.

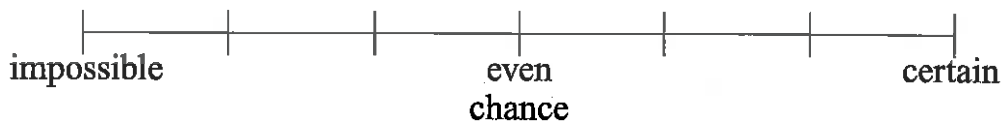

26. On Sports Day, five girls took part in the 400 metre race.
Their times were recorded in the table below.

name	time taken
Angie	1 min 18 sec
Bella	1 min 25 sec
Clemmie	1 min 13 sec
Davina	1 min 22 sec
Erin	1 min 19 sec

- (a) Who came second in the race?

Answer:

- (b) Who finished 6 seconds ahead of Erin?

Answer:

- (c) How many seconds behind the winner was the person who came last?

Answer: sec

-
27. A large barrel contains 3.25 litres of water.

Mel fills three 500 ml bottles from the barrel.

She uses all of the rest of the water to fill as many 150 ml cups as she can.

What is the largest number of cups which Mel can completely fill?

Answer:



28. Sarah has almost completed a bar chart to show the number of pets owned by each of the 26 girls in class 6A.

No-one has more than 5 pets.

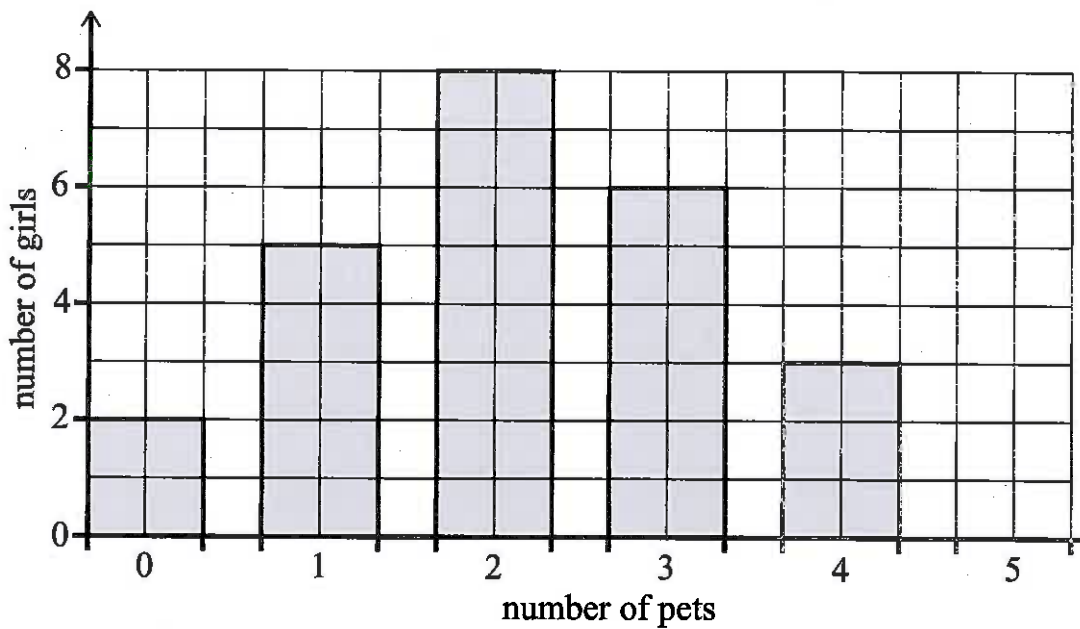

(a) How many girls have 3 pets?

Answer:

(b) Complete the bar chart by drawing the bar to show the number of girls who have 5 pets.

(c) How many pets are owned altogether by the 26 girls?

Answer:



29. The diagram below shows 4 right-angled triangular pieces of card.

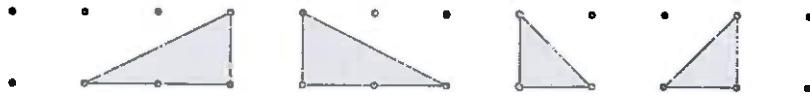

These pieces of card can be put together to form geometrical shapes.

The pieces of card could be turned upside down or rotated if necessary.

On the grid below, the 4 pieces have been put together to form a pentagon.

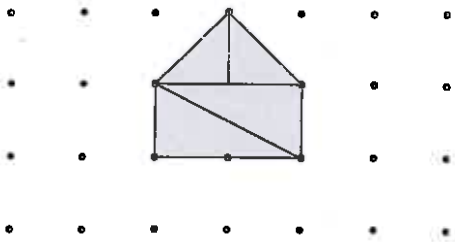

On each grid below, draw a diagram to show how all 4 pieces of card could be put together to form:

(a) a rectangle

(b) a trapezium with one line of symmetry

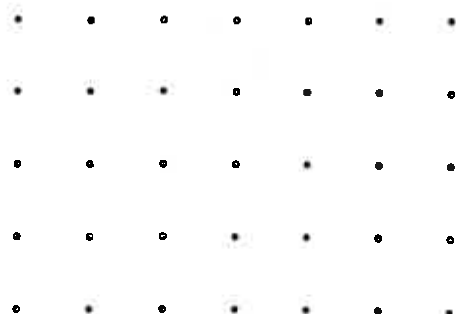
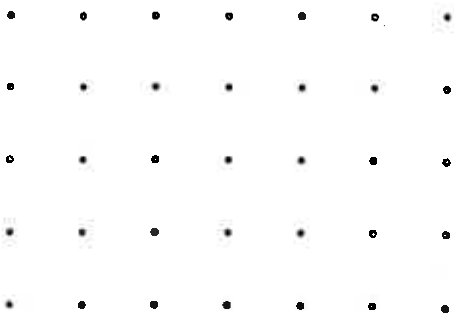

(c) a parallelogram

(d) a kite

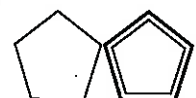
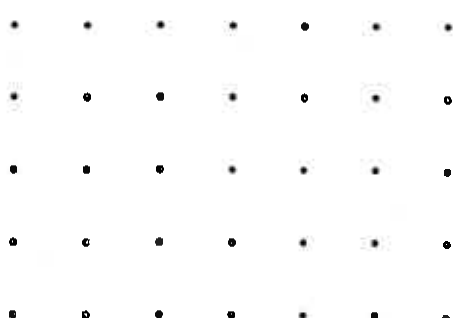
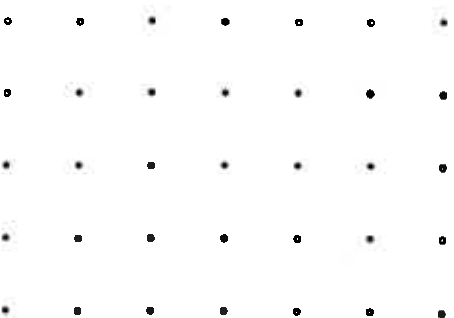

30. On the Gagalapos Islands, there lives an amazing animal called the Joak.

When it is born, the Joak has one head with a bristle, and one body segment with two pairs of bristles, as shown:

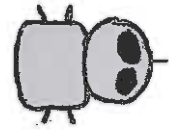

At the start of each year, a Joak grows one more identical body segment so that at the start of the second year it looks like this:

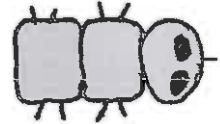

(a) In the space below, draw a sketch of a Joak at the start of its third year.

(b) Complete the table below.

start of year	number of segments	number of bristles
1 (when born)	1	5
2	2	9
3		
4		
5		

(c) How many bristles will a Joak have during its 10th year?

















Answer:

(d) In which year will a Joak have 65 bristles?

Answer:





31. In the grid below, each symbol represents a number.
The total of each row and column is shown.
Work out which number each symbol represents.

					total 25
					23
					26
					28
total	27		26	24	

Answer:  =

 =

 =

 =

 =

32. Thomasina, Dixie and Harriet are playing a game of marbles.
They start with 20 marbles each and they play three rounds.
In the first round, Dixie wins 4 marbles from Thomasina and loses 5 to Harriet.
In the second round, Harriet wins 6 marbles from Dixie and loses 2 to Thomasina.
In the third round, Thomasina wins 3 marbles from Harriet and loses 6 to Dixie.
How many marbles does each girl have at the end of the three rounds?

name	number of marbles
Thomasina	
Dixie	
Harriet	

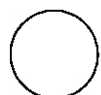

33. Carla has some coloured plastic tiles.

Her tiles are in the shape of a square, circle, star or triangle, and are either black, grey or white.

(a) Complete the table to show all of the different possible types of tile.

	square	circle	star	triangle
black (B)	B □			
grey (G)		G ○	G ☆	
white (W)			W ☆	W △

Carla has each type of tile in a small size and a large size.

She has 24 tiles altogether.

(b) What fraction of the tiles are black?

Answer:

(c) How many of the tiles are in the shape of a star?

Answer:

Below are three of her tiles.



The small grey square differs from the large black circle in 3 ways: size, colour and shape.

(d) Describe a tile which differs from the small white triangle in 1 way.

Answer:

(e) How many tiles differ from a large grey star in 3 ways?

Answer:



34. The model shown below is made from 3 identical cuboids.

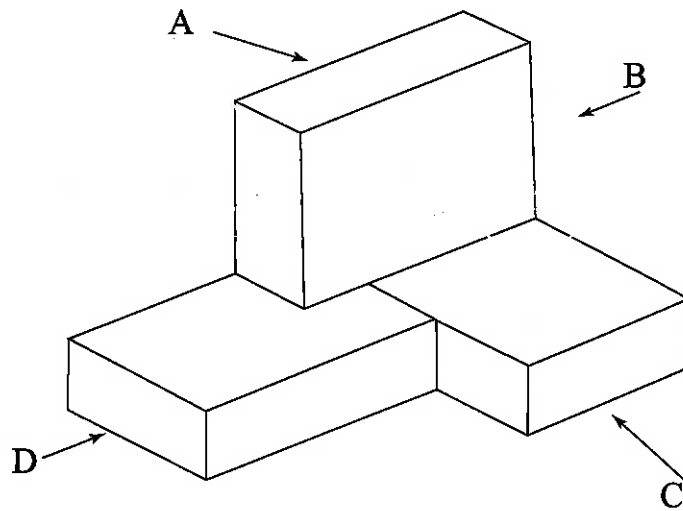

From which direction, A, B, C or D, are the following views taken?

(a)

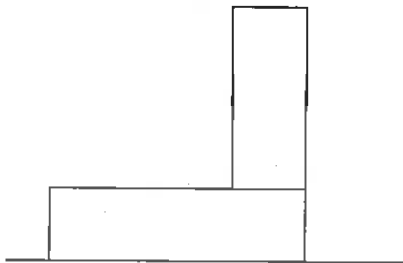

Answer:.....

(b)

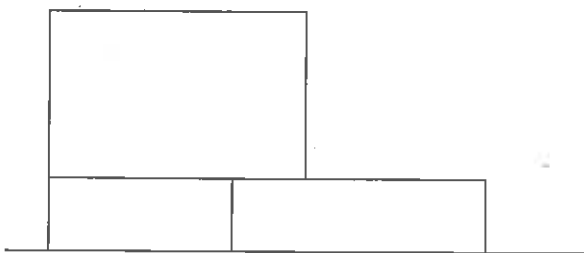

Answer:.....

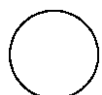

35. In the diagrams below, the square and rectangle have the same perimeter.
 The square has an area of 64 cm^2 .
 The length of the rectangle is three times the width of the rectangle.

Work out the length of the rectangle.

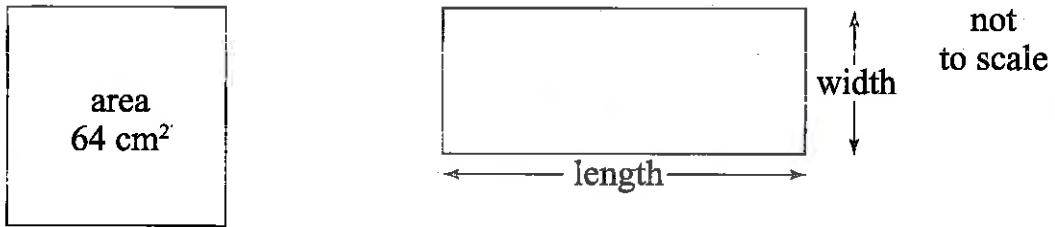

Answer: cm

36. In the following diagrams, the number underneath is calculated using a rule.
 The rule is “**multiply the numbers in the white regions and then add the numbers in the grey regions.**”
 The total is written underneath the diagram.

For example:

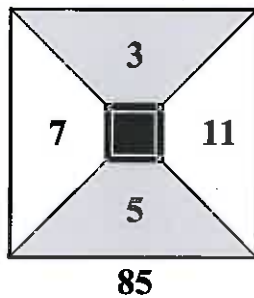

Fill in the dotted lines to complete the following diagrams.

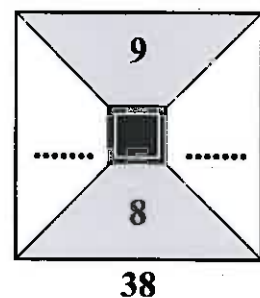
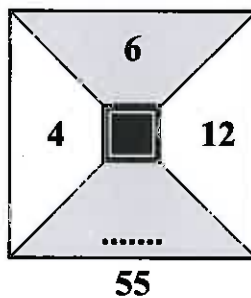
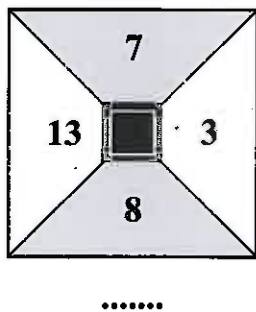

37. The diagram below shows the footpaths between different villages.
 Each village is represented by a letter.
 For example, there are 3 different possible footpaths between villages Q and R.

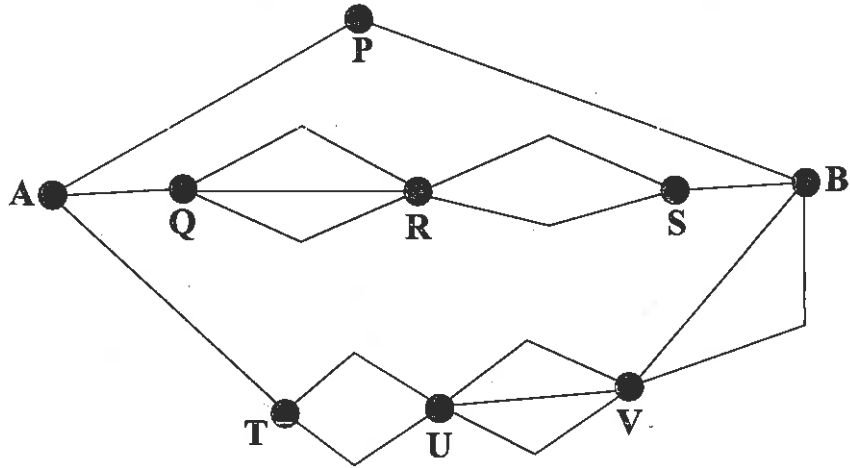

Jane wants to walk from village A to village B without travelling through any village twice on her route.

Work out how many different possible routes Jane could take.

Answer:

TURN OVER FOR QUESTION 38

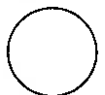

38. Magda and her friends go to the cinema.

They buy 1 large tub of popcorn, 4 fizzy drinks and 10 packets of crisps.

The bill comes to £10.89

Lena and her friends go to the cinema.

They buy 1 large tub of popcorn, 3 fizzy drinks and 7 packets of crisps.

The bill comes to £8.64

How much would it cost to buy 1 large tub of popcorn, 1 fizzy drink and 1 packet of crisps?

Answer: £.....

(Total: 100 marks)



283008

24