

# City of London School for Girls

The North London Independent Girls' School Consortium

Entrance Examination – Group 2

Friday 14<sup>th</sup> January 2011

MATHEMATICS

Time: 1 hour 15 minutes

1. 
$$\begin{array}{r} 5924 \\ + 3578 \\ \hline \\ \hline \end{array}$$

2. Subtract 248 from 2396.

.....

3. Multiply 57 by 8.

.....

4. Divide 21060 by 9.

.....

5. Calculate  
 $2.7 - 0.47$

.....



6. Arrange all the digits 9, 7, 6, 4, 2 to make the smallest even number.

.....

7. Neha won twelve thousand and eighteen pounds in a lottery. Jasmine won three hundred and nine pounds. How much did they win altogether? Give your answer in figures, not words.

.....

8. Circle two numbers which have the same value.

$8\frac{1}{20}$        $\frac{17}{2}$       8.1      8.05       $8\frac{1}{5}$

9. Put the correct number in the box.

+ 18 = 8 × 4

10. What is  $\frac{3}{7}$  of 385?

.....

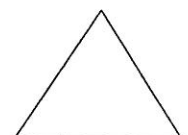

11. The timetable below shows information about the overnight train from London to Scotland.

|                          |              |      |
|--------------------------|--------------|------|
| London Euston Station    | (Fri) depart | 1957 |
| Birmingham International | (Fri) depart | 2107 |
| Glasgow                  | (Sat) arrive | 0645 |

How long does the train take

- a) from London Euston to Birmingham International?

\_\_\_ hrs \_\_\_ min

- b) from London Euston Station to Glasgow?

\_\_\_ hrs \_\_\_ min

12. Draw a reflection of the shape in the given line.

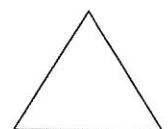
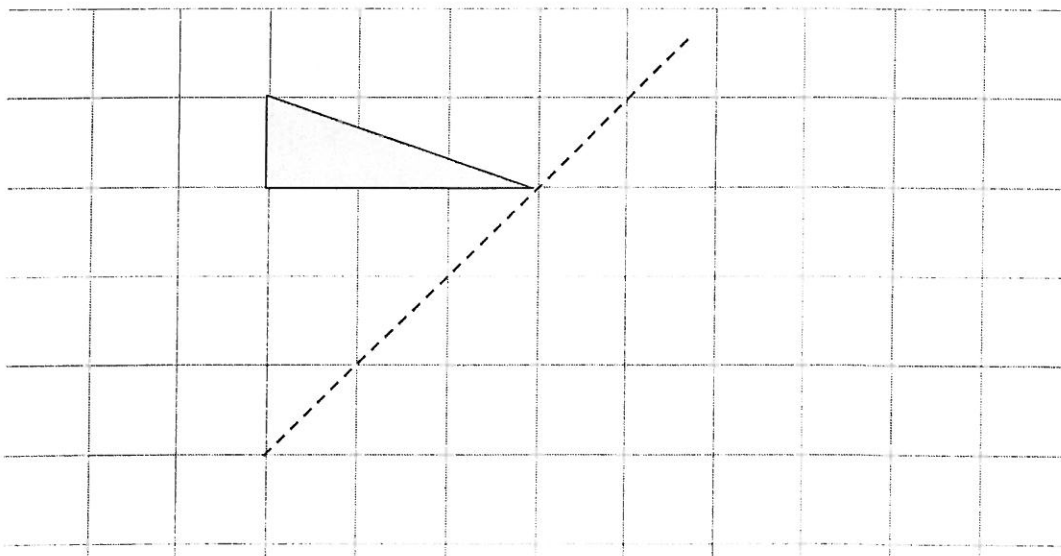

13. In a survey, the hair colour of a set of girls was recorded. The results are shown on the bar chart below.

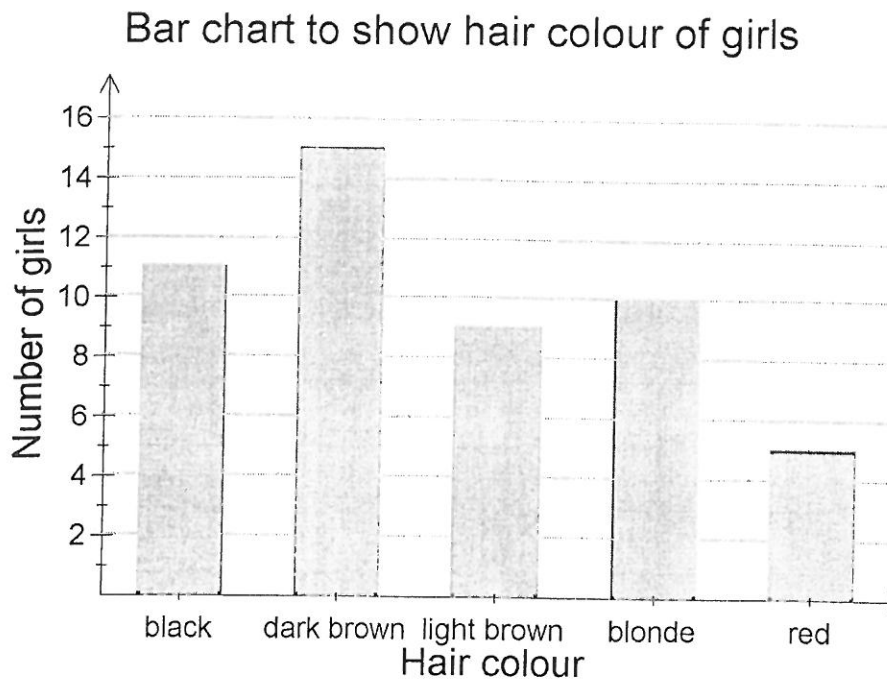

- a) Complete the table below.

| Hair colour | Number of girls |
|-------------|-----------------|
| Black       | 11              |
| Dark brown  | 15              |
| Light brown | 9               |
| Blonde      | 10              |
| Red         |                 |

- b) What percentage of girls have brown hair?

.....

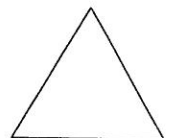

14. There are 200 pupils on a school trip. Each coach only holds 34 pupils. How many coaches will the school need to book?

.....

15. What fraction of the shape is shaded?

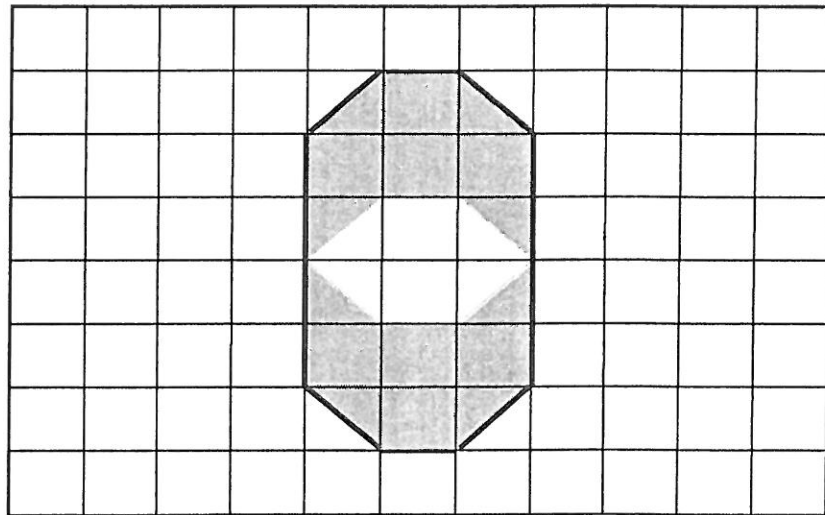

.....

16. In a 24 hour day, what are the two possible times of day shown by the clock?

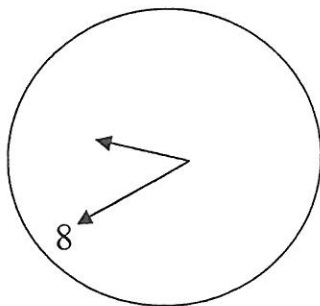

..... and .....



17. The difference between two numbers is 7.  
When the numbers are multiplied, the result is 60.  
What are the two numbers?

..... and .....

18. On the blank grid, draw a **rectangle** of the same area as the picture below.

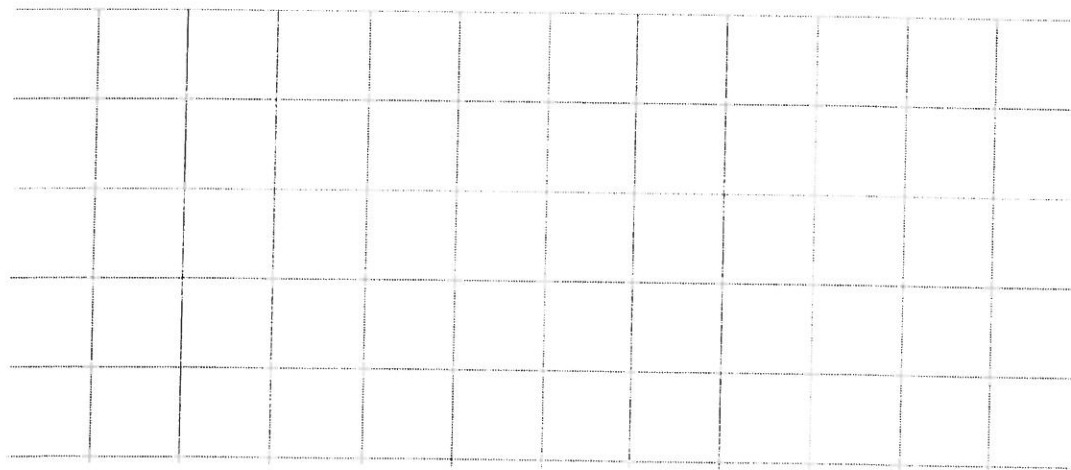
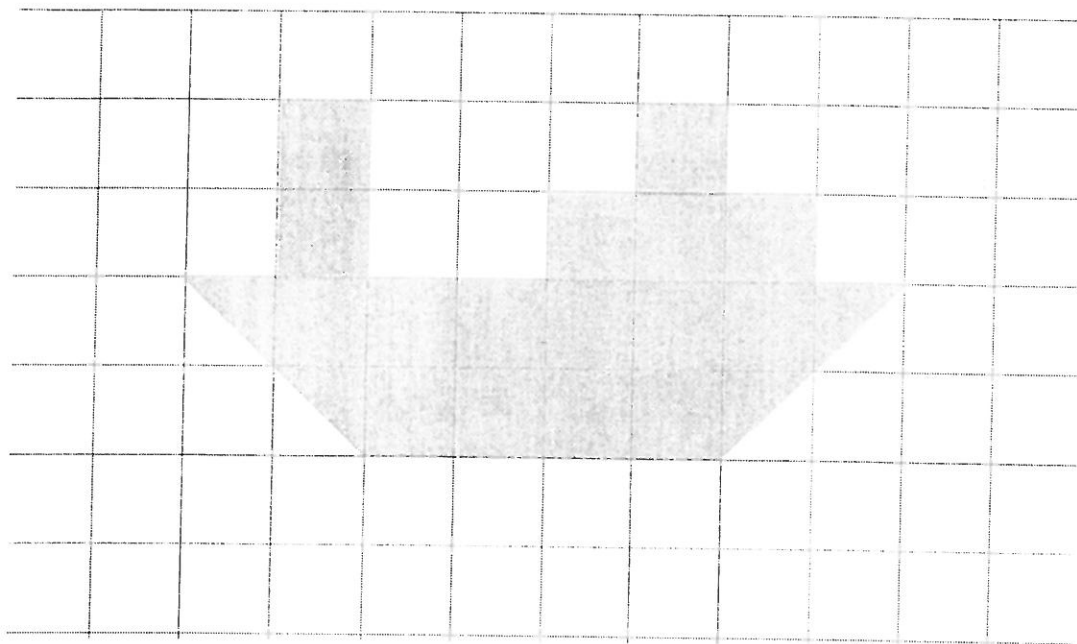

19. Joanna gets £5.00 pocket money each week and her younger sister, Amy, gets £3.50 each week. After 5 weeks, Joanna saved all her money, but Amy spent 75p a week on stickers. How much more does Joanna now have compared to Amy?

.....

20. Continue each sequence by giving the next two terms.

a) 8, 13, 18, 23, \_\_\_\_\_, \_\_\_\_\_

b) 13, 8, 3, -2, \_\_\_\_\_, \_\_\_\_\_

c)  $\frac{1}{256}, \frac{1}{64}, \frac{1}{16}, \frac{1}{4},$  \_\_\_\_\_, \_\_\_\_\_

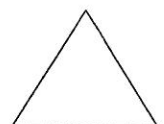



21. Look carefully at the function machine below. Each stage of the machine performs a different operation, but identical shapes have the same operation.

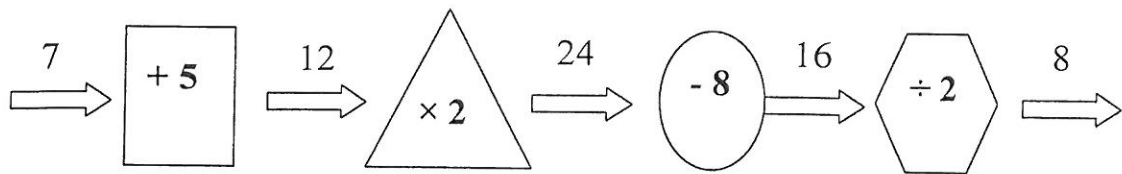

The same function machine has been used below. Work out the missing input or output in each case shown.

a)

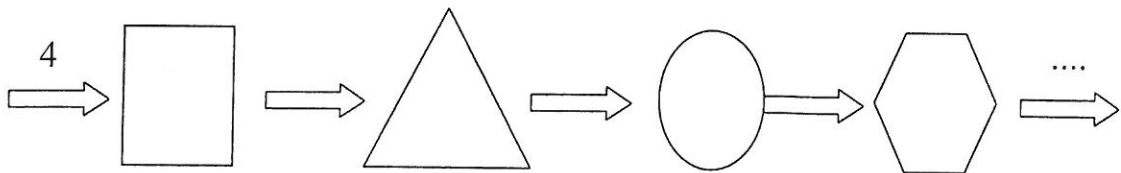

b)

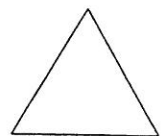
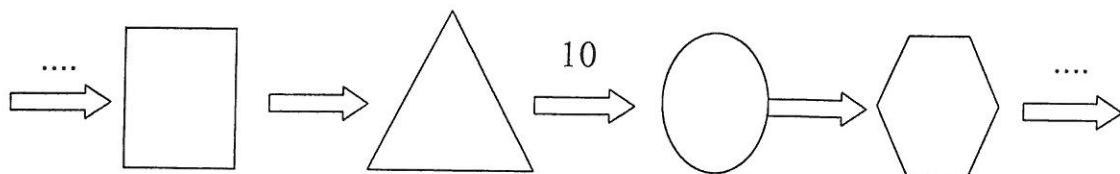

22. Belinda has a digital alarm clock.

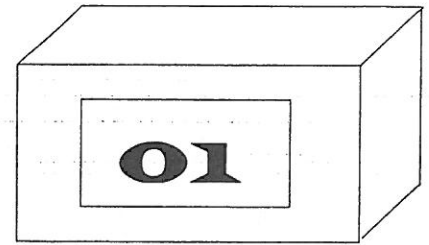

The numbers on the clock are displayed as:



Belinda's digital clock shows the time 01:10

She puts it upside down on her bedside table.

The same time is shown.

At what times between 01:10 and 12:00 does the clock show the same time when it is upside down as when it is the right way up?

.....

23.  $ABCD$  is a four digit number

- Its first digit is  $\frac{1}{4}$  of its last digit
- The second digit is 1 less than its first digit
- When you multiply  $ABCD$  by 4, its digits appear in reverse order
- None of the digits are the same

What is the number?

.....

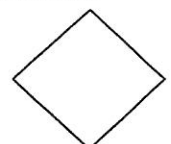

24. Look at this pattern:

$$\begin{aligned}6 \times 6 &= 36 \\66 \times 66 &= 4356 \\666 \times 666 &= 443556 \\6666 \times 6666 &= 44435556\end{aligned}$$

a) Use the pattern to fill in the spaces:

$$\underline{\hspace{2cm}} \times \underline{\hspace{2cm}} = 44444435555556$$

b) How many digits are in the answer to

$$6666666666 \times 6666666666?$$

.....

25. Janice has 10 pens  
5 are blue pens and 5 are red.  
8 are felt tip pens

Fill in the blanks in this statement:

There are between \_\_\_\_\_ and \_\_\_\_\_ blue felt tip pens.

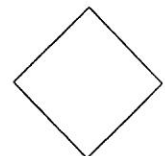

26. This shape has an area of  $63\text{cm}^2$ .  
It is made from square tiles.  
Find the perimeter of the shape.

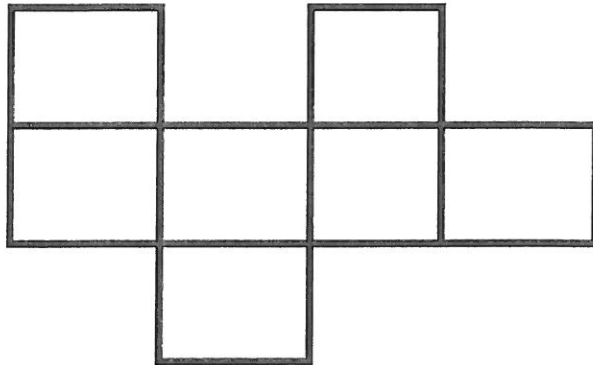

.....

27. 48 cats eat 12 cans of food in 3 days

Fill in the spaces:

12 cats eat \_\_\_\_\_ cans of food in 3 days

48 cats eat 24 cans of food in \_\_\_\_\_ days

24 cats eat \_\_\_\_\_ cans of food in 18 days

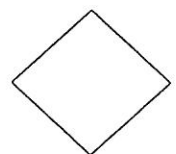

28. I only have five coins in my purse. They are 1p, 2p, 5p, 10p and 20p. It is not possible to make exactly 19p with these coins.

a) What is the smallest amount that can not be made using my coins?

.....

b) Find the two other amounts, less than 20p, which I cannot make.

.....

c) The largest amount of money that can be made using these coins is 38p. Find the largest amount of money less than 38p which can not be made using these coins.

.....

29. Two identical square holes are cut from a rectangular sheet leaving an area of 58 square centimetres. How long are the sides of the square?

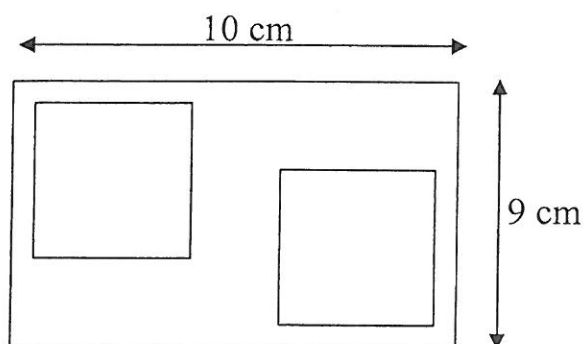

.....

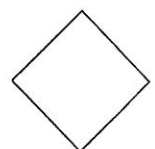

30. In the following pattern, you can only move from a letter to a letter immediately below it but slightly to the side in the next line.

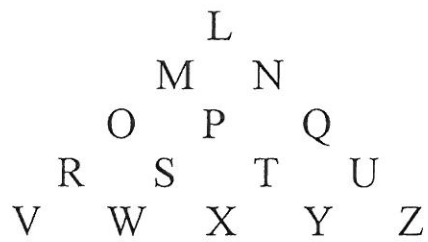

One route from L to W is LMOSW

- a) Write down a route from L to Y that goes through Q

.....

- b) Write down all the possible routes from L to W

.....

- c) How many possible routes are there from L to X?

.....

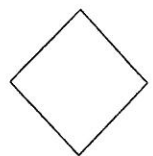

31. Jane is making a spiral out of wire. She bends the wire after 1 cm, then bends the wire after 2 cm, then 3 cm and continues in this manner.

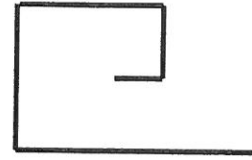

After 4 bends she has used 15 cm of wire

Complete the table

| Number of Bends          | 1 | 2 | 3 | 4  |
|--------------------------|---|---|---|----|
| Centimetres of wire used |   |   |   | 15 |

How much wire will she have used after 6 bends?

.....

How many bends will Jane have made if she uses 66 cm of wire?

.....

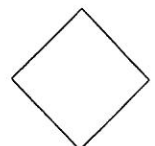

32. Some fairy cakes are delivered for Janey's party.

Janey can use big plates or small plates to put the cakes on.

If she uses big plates she can put seven cakes on each plate with five left over.

If she uses small plates she can put five cakes on each plate with three left over.



What is the smallest number of cakes that were delivered for Janey's party?

.....

The smallest number of cakes are delivered for Janey's party.

a) If she only used big plates for the cakes, how many big plates would she need?

.....

c) If she only used small plates for the cakes, how many small plates would she need?

.....

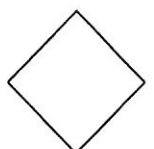



33. The sweet shapes below cost 52p altogether. Each heart costs half the price of a triangle and each star costs double the cost of each triangle. What is the cost of a heart?

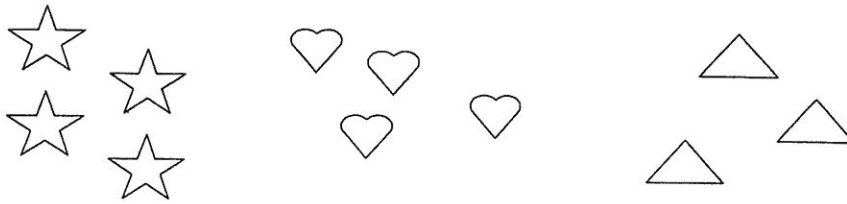

.....

34. A factory recycles paper cups for use in its canteen. Seven used cups are needed to make each new cup. From 721 used cups, how many new cups can be made **in total**, if **all the used cups get recycled**?

.....

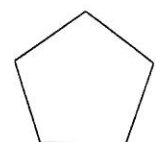

35. Below is an equilateral triangle with a total area of  $128 \text{ cm}^2$ . Find the total **shaded** area.

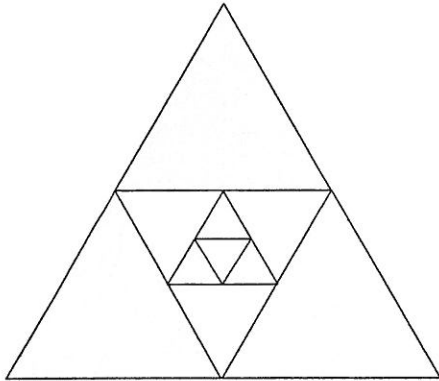

.....

36. I bought a packet of fruit gums and ate 2 of them, secretly, in my Music lesson.  
At break, I shared one third of the remaining fruit gums with my friends. I then finished the fruit gums, eating an equal amount in each of the next four lessons.  
What is the smallest number of fruit gums there could have been in the packet?

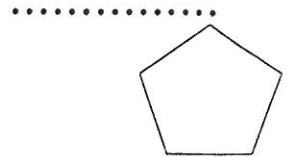

37. A piece of paper with letters written on it is folded in half, so that the letters A, B, C, D, E, F, G, H, are on the top.

|   |   |   |   |
|---|---|---|---|
| A | B | C | D |
| E | F | G | H |
| I | J | K | L |
| M | N | O | P |

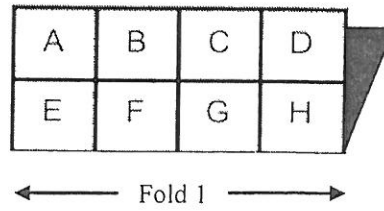

Now the letter M is under the letter A.

- a) Which letter is under the C      Answer:.....

The paper is folded again so that A, B, E and F are on top.

Under A are the letter M, P and D in that order.

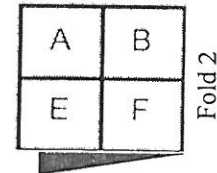

- b) Working from top to bottom:

Which letters are under B? .....

Which letters are under E? .....

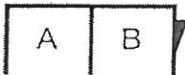
- c)   
Fold 3

After another fold, which letters are under B? Write the letters in order from top to bottom.

.....

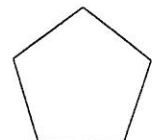

38. Pia has three cards. Card A tells her to multiply by 5, card B tells her to add 3 and Card C tells her to divide by 2.

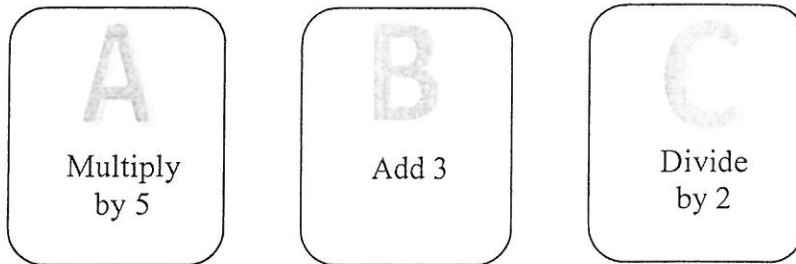

Pia arranges her cards in the order A B C and starts with the number 3. Her answer is 9.

- a) If Pia keeps her cards in the order A B C and starts with 11, what is her answer?

.....

- b) What whole number would she need to start with to get an answer of 19, if her cards were still arranged in the order ABC?

.....

- c) If Pia arranges her cards in the order C B A and starts with number 4, what is her answer?

.....

- d) Pia changes the order of the cards. She starts with a whole number and ends up with 15. Give all the possible orders in which she could have used her three cards.

.....

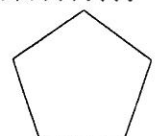

39. Zadoc the space explorer has discovered a strange planet where they have different symbols to describe mathematical operations. They are  $\diamond$ ,  $\otimes$ ,  $\oslash$ ,  $\oplus$  and  $\#$ .

He worked out that  $\diamond$  means 'Add the two numbers and then multiply the result by itself'.

So  $3 \diamond 2 = (3 + 2) \times (3 + 2) = 5 \times 5 = 25$

a) Find  $1 \diamond 4$  .....

He also found that  $\otimes$  means 'Add the two numbers and subtract 3'

b) Find  $5 \otimes 7$  .....

Use the examples to find the meaning of the other new symbols and use them to answer the questions.

c)  $5 \oslash 1 = 7$   
 $3 \oslash 4 = 11$   
 $1 \oslash 7 = 15$

Find  $5 \oslash 2$  .....

d)  $8 \oplus 3 = 7$   
 $4 \oplus 2 = 4$   
 $6 \oplus 6 = 9$

Find  $12 \oplus 1$  .....

e)  $3 \# 4 = 12$   
 $5 \# 9 = 19$   
 $8 \# 2 = 15$

Find  $2 \# 6$  .....

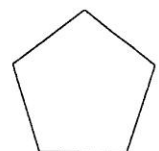

40. A set of 5 square based boxes are made from centimetre cubes and each box fits exactly inside each other, with the tops level. The dimensions of the largest box are 14 x 14 x 13

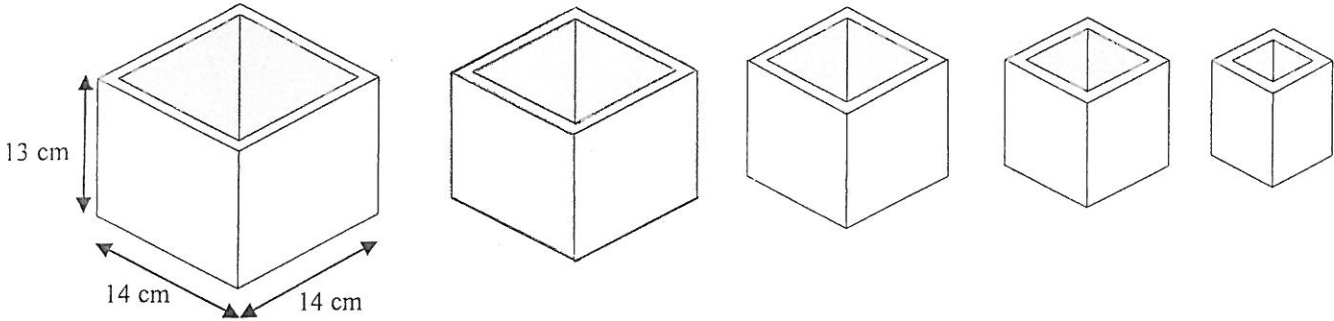

a) What are the dimensions of the second box?

.....

b) What are the dimensions of the smallest box?

.....

c) How many cubes are used to make the third box?

.....

